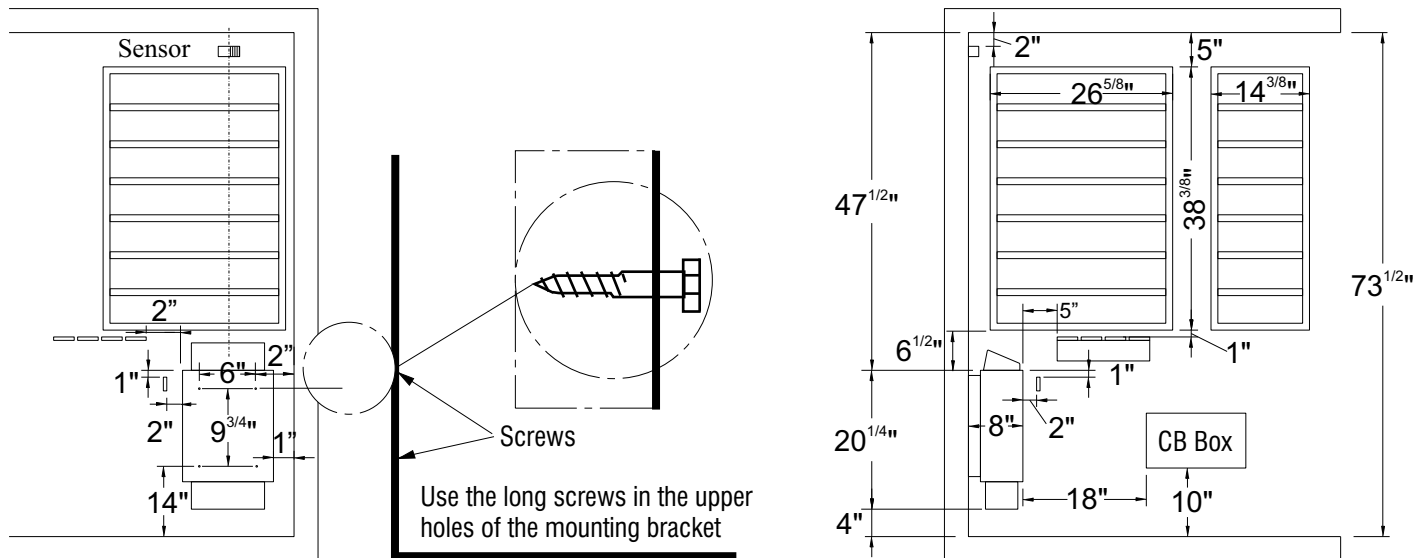

DIAGRAM 1 (Junior Heater 1517-30-02)

MINIMUM DISTANCE TO COMBUSTIBLE MATERIAL



Recheck your distances from the heater to combustible materials to be sure you have the proper minimum distances.

⚠ OBSERVING MINIMUM DISTANCES IS REQUIRED TO REDUCE FIRE HAZARD

CAUTION: Avoid fire, Do Not Place Combustible Material on sauna heater / ATTENTION: Evitez les Incendies, Ne Placez Aucune Matière Combustible Sur Le Chauffe-saun

TABLE 1

*Optional IR System	IR kW	Sauna kW	* Optional Traditional Heater	MINIMUM ROOM			MAXIMUM ROOM		PHASE	VAC	IR AMPS	WIRE SIZE		
				Floor Area	Ceiling Height	Volume Cu.Ft.	Ceiling Height	Volume Cu.Ft.				Power Supply to CB 14	CB 14 to IR Heating Panels	CB 14 to Traditional Heater
IS-201/202	1.6	3.0	Junior 3.0	12 sq. ft.	73 1/2"	100	84"	150	1	240	6.5	2 #12AWG+GR	2 #14AWG+GR	2 #12AWG+GR

Note: Two Tier Benching is mandatory for Traditional and IR Systems.

IR Heating Panel Quantities			
MODEL	IR-325-240	IR-160-240	IR-110-240
IS-201	4	1	1
IS-202	3	3	1

NOTE: All installation and service to this equipment should be performed by qualified licensed personnel in accordance with local and national codes.

NOTE: A GFCI (Ground Fault Interrupt Circuit) device is not required by NEC. A GFCI may be installed if required by local codes but will nuisance trip during use of the product.

CAUTION: Loose wire connections can cause heat damage to wires, terminal blocks and other components and may void the warranty.

DIAGRAM 2 (Viki Heater (1720-xx-02) and Designer Heater (1712-xx-0207))

MINIMUM DISTANCE TO COMBUSTIBLE MATERIAL

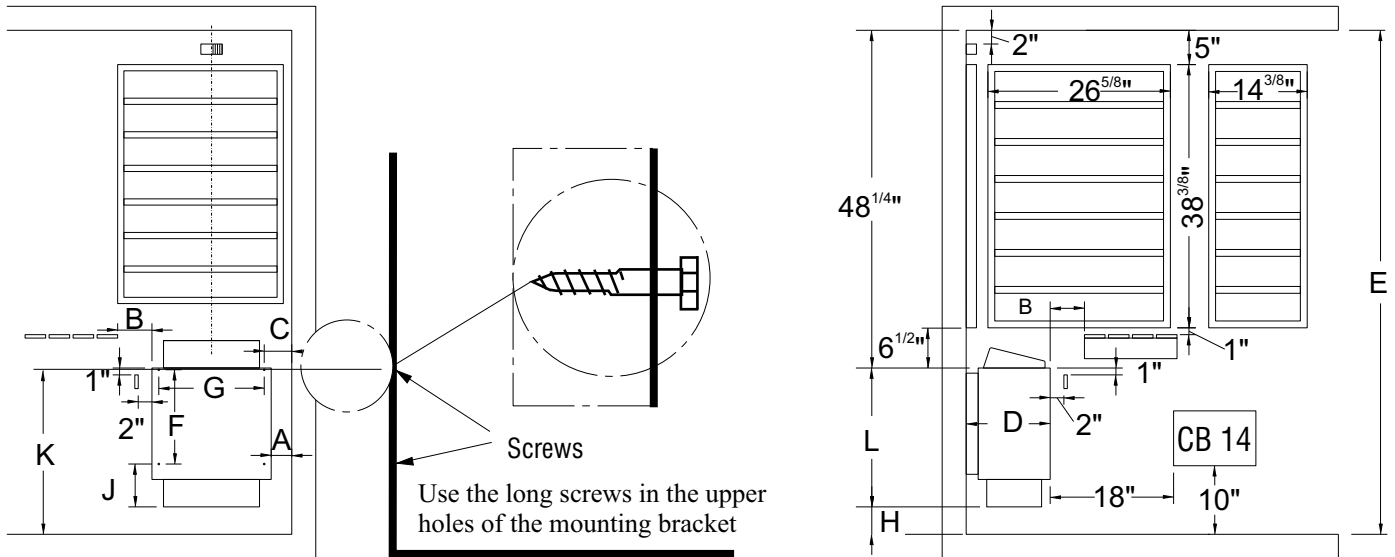

Recheck your distances from the heater to combustible materials to be sure you have the proper minimum distances.

! OBSERVING MINIMUM DISTANCES IS REQUIRED TO REDUCE FIRE HAZARD

IR Heating Panel Quantities			
MODEL	IR-325-240	IR-160-240	IR-110-240
IS-301	5	1	2
IS-401	6	1	2
IS-601	8	1	2
IS-302	4	3	2
IS-402	5	3	2
IS-602	7	3	2

Heater kW	Minimum Distance										
	A	B	C	D	E	F	G	H	K	J	L
Viki 4.5	3.0"	4.0"	3 5/8"	12 1/4"	73 1/2"	13 3/4"	15 3/8"	4"	24"	6 1/4"	20 1/4"
Viki 6.0	4.0"	5.0"	4 5/8"	12 1/4"	73 1/2"	13 3/4"	15 3/8"	4"	24"	6 1/4"	20 1/4"
Viki 8.0	5.0"	6.0"	5 5/8"	12 1/4"	73 1/2"	13 3/4"	15 3/8"	4"	24"	6 1/4"	20 1/4"
Designer 4.5	3.0"	4.0"	3 5/8"	11 1/2"	74"	6"	14 3/8"	6 1/2"	23"	10 1/2"	18 1/2"
Designer 6.0	4.0"	5.0"	4 5/8"	11 1/2"	74"	6"	14 3/8"	6 1/2"	23"	10 1/2"	18 1/2"
Designer 8.0	5.0"	6.0"	5 5/8"	11 1/2"	74"	6"	14 3/8"	6 1/2"	23"	10 1/2"	18 1/2"

TABLE 2

IR System	IR kW	Sauna kW	Sauna Heater	Minimum Room			Maximum Room			Phase	VAC	IR Amps	Sauna Amps	WIRE SIZE		
				Floor Area	Ceiling Height	Volume Cu.Ft.	Ceiling Height	Volume Cu.Ft.	Power Supply to CB 14					CB 14 to IR Heating Panels	CB 14 to Traditional Heater	
IS-301 or 302	2.0	4.5	Viki 4.5 Designer 4.5	16 sq. ft.	73 1/2"	135	* 96"	200	1	208	7.2	21.6	2 #10AWG+GR	2 #14AWG+GR	2 #10AWG+GR	
									1	240	8.4	18.8	2 #10AWG+GR	2 #14AWG+GR	2 #10AWG+GR	
IS-401 or 402	2.3	6.0	Viki 6.0 Designer 6.0	21 sq. ft.	73 1/2"	175	* 96"	300	1	208	8.4	28.8	2 #8AWG+GR	2 #14AWG+GR	2 #8AWG+GR	
									1	240	9.7	25.0	2 #10AWG+GR	2 #14AWG+GR	2 #10AWG+GR	
IS-601 or 602	3.0	8.0	Viki 8.0 Designer 8.0	31 sq. ft.	73 1/2"	250	* 96"	425	1	208	10.8	38.5	2 #8AWG+GR	2 #14AWG+GR	2 #8AWG+GR	
									1	240	12.3	33.3	2 #8AWG+GR	2 #14AWG+GR	2 #8AWG+GR	

Note: 84" Ceiling Maximum for rooms with IR Systems to ensure proper heat performance.

Note: Two Tier Benching is mandatory for Traditional and IR Systems.

NOTE: All installation and service to this equipment should be performed by qualified licensed personnel in accordance with local and national codes.

NOTE: A GFCI (Ground Fault Interrupt Circuit) device is not required by NEC. A GFCI may be installed if required by local codes but will nuisance trip during use of the product.

CAUTION: Loose wire connections can cause heat damage to wires, terminal blocks and other components and may void the warranty.

DIAGRAM 3

Typical IS Installation with a Traditional Sauna Heater

Refer to Diagram 1 and 2 for minimum spacing requirements depending on the traditional sauna heater.

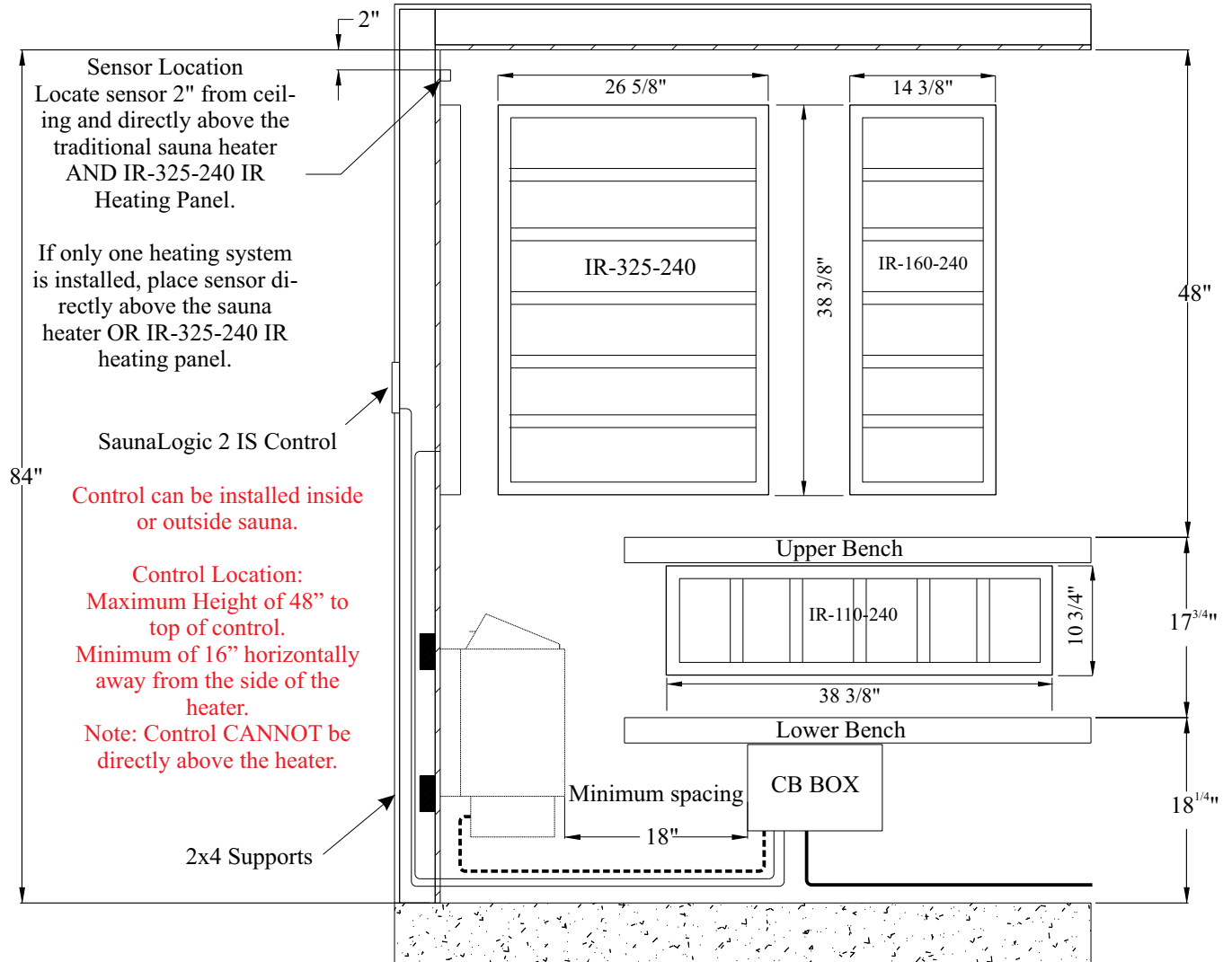

CB Box can be outside of the sauna room or installed inside sauna room.

DIAGRAM 4

DIAGRAM 5

SL2 IS Control

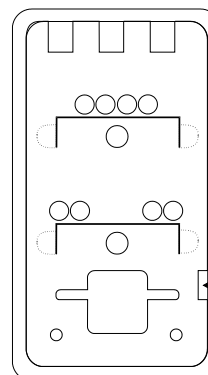
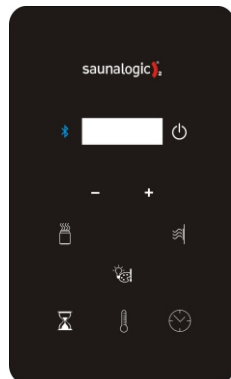

Back of sensor

Insert screwdriver tip here to unsnap sensor cover from sensor. Note vertical orientation of cover before removing.

DIAGRAM 6

Surface Mounted IR Heating Assembly Information

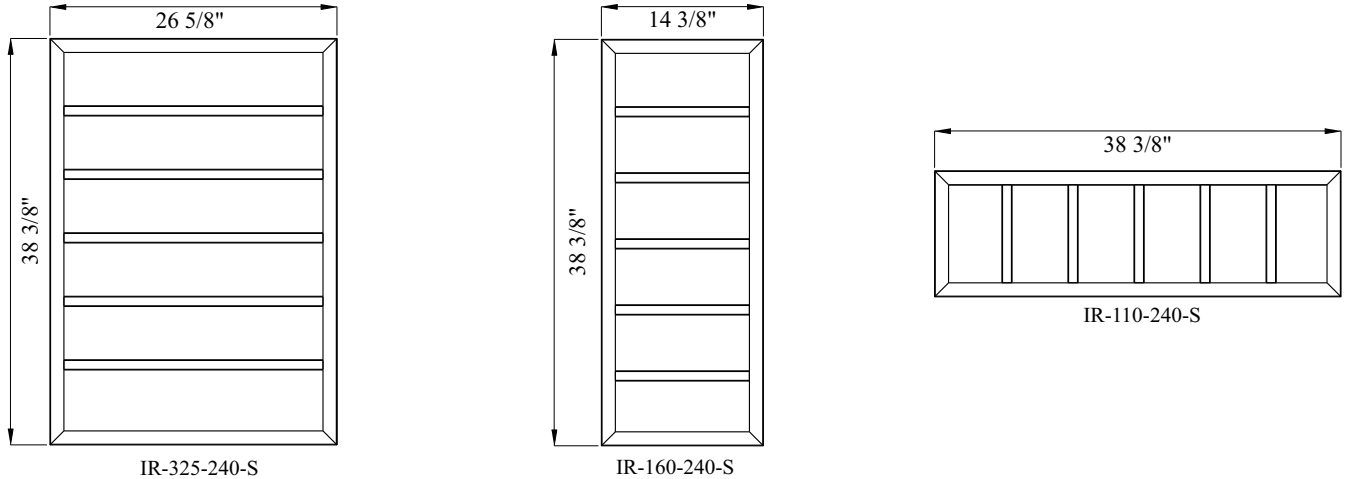

DIAGRAM 7 CB 14-1 BOX

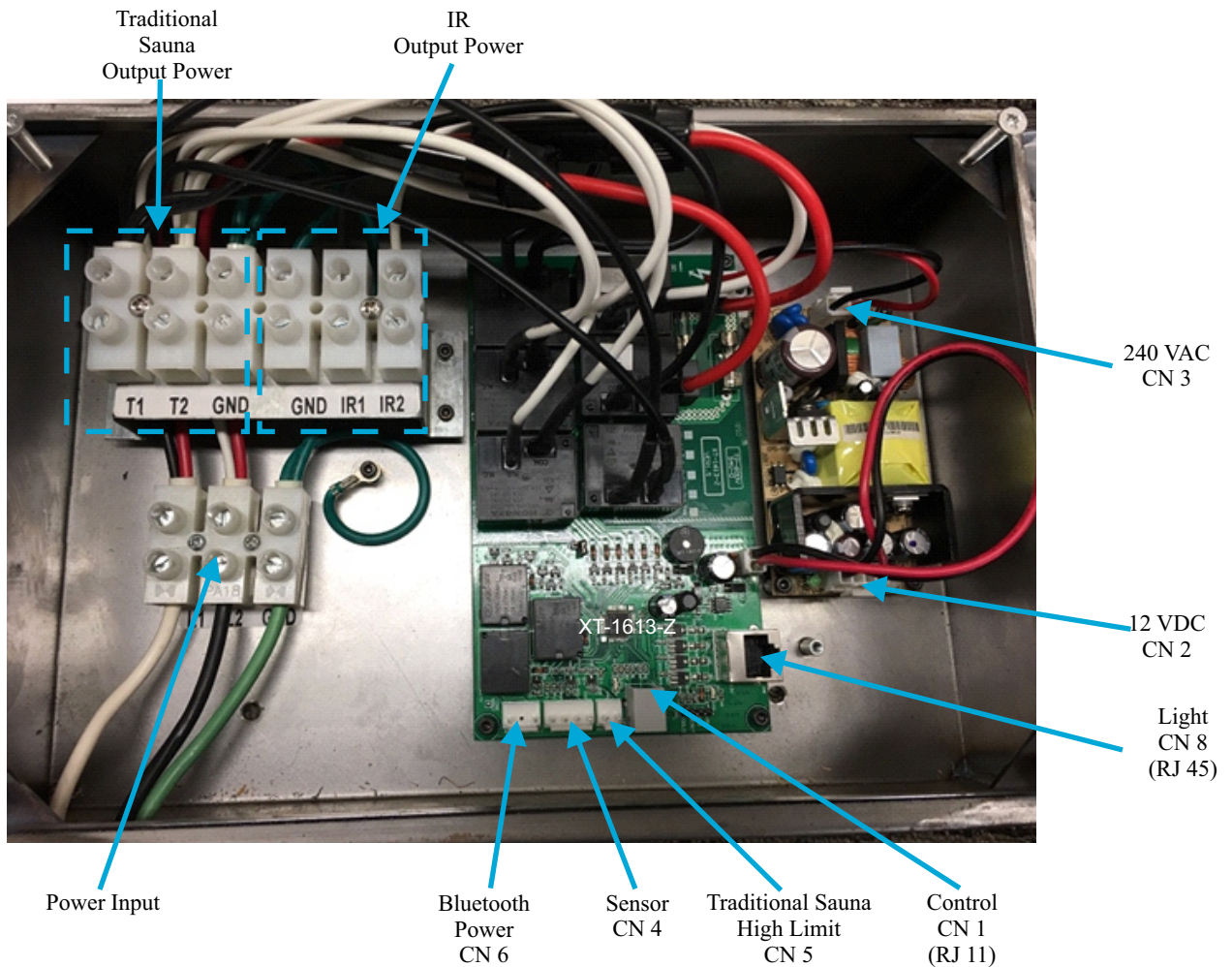

DIAGRAM 8

WIRING DIAGRAM: CONTROL AND HEATER MODELS

Junior 3.0 (1517-30-02) with SL2 IS and CB 14-1 Box

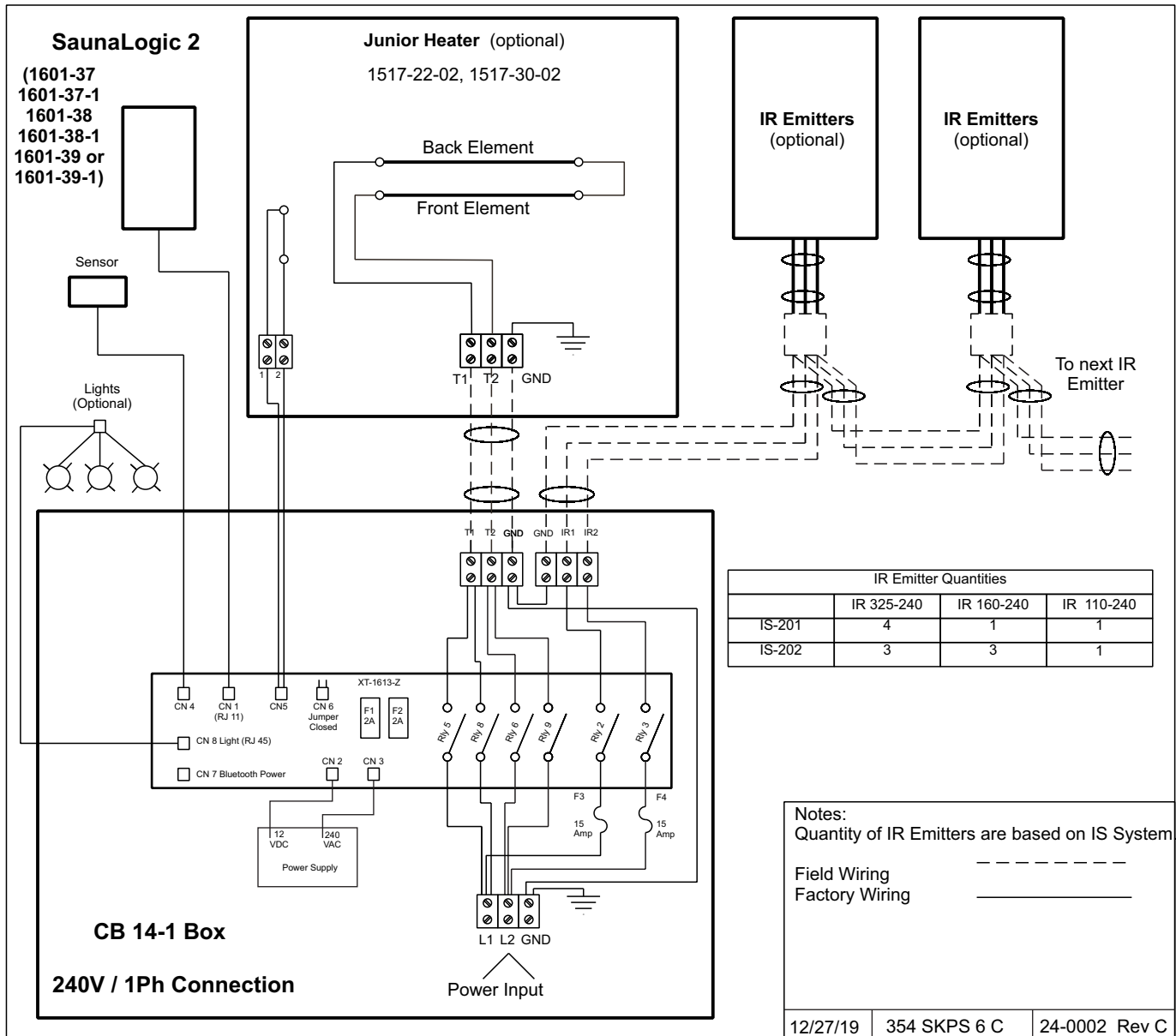

DIAGRAM 8 CONT.

WIRING DIAGRAM: CONTROL AND HEATER MODELS Viki 4.5, 6.0 & 8.0 (1720-45-02, 1720-60-02, 1720-80-02) with SL2 IS and CB 14-1 Box

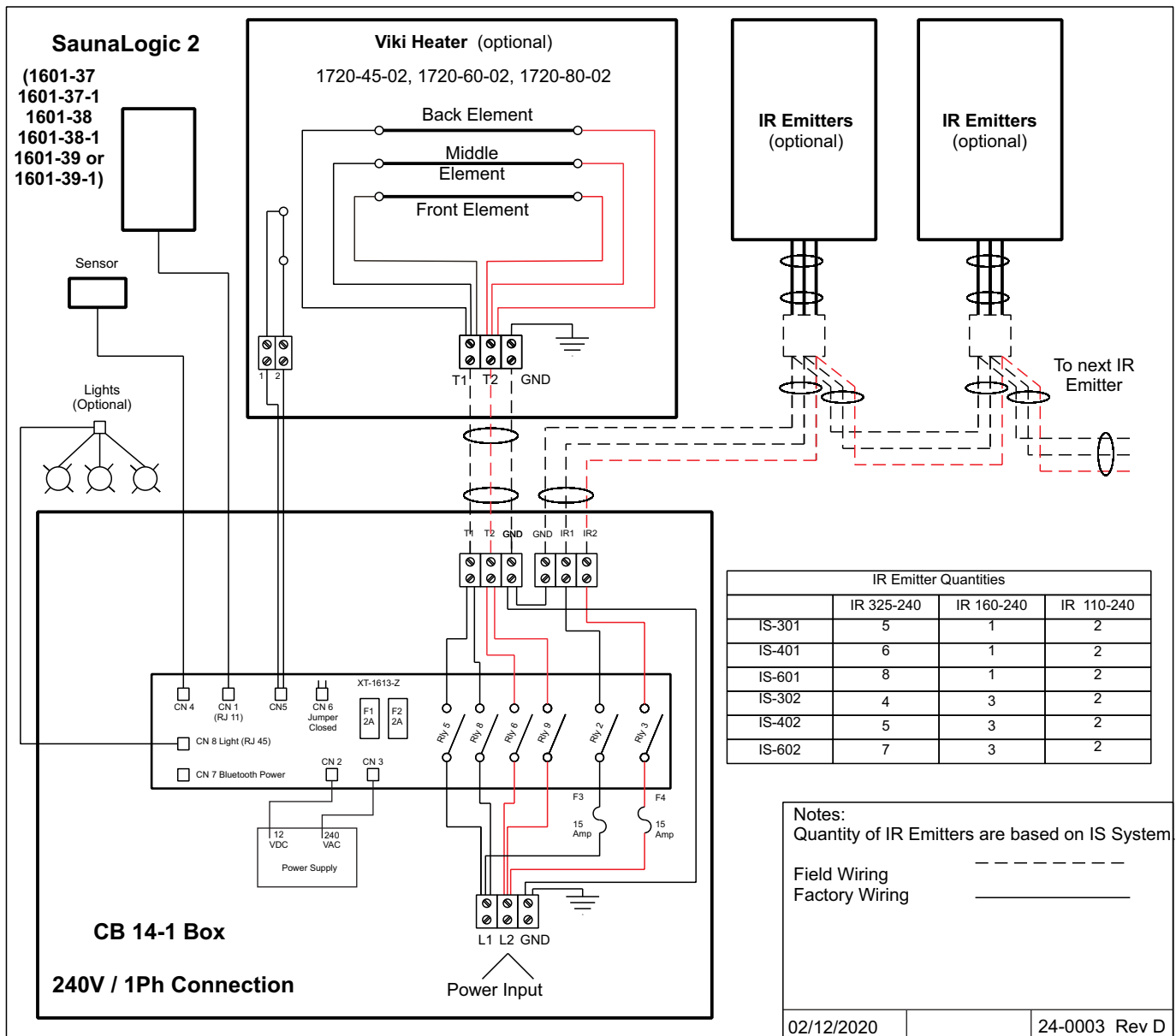
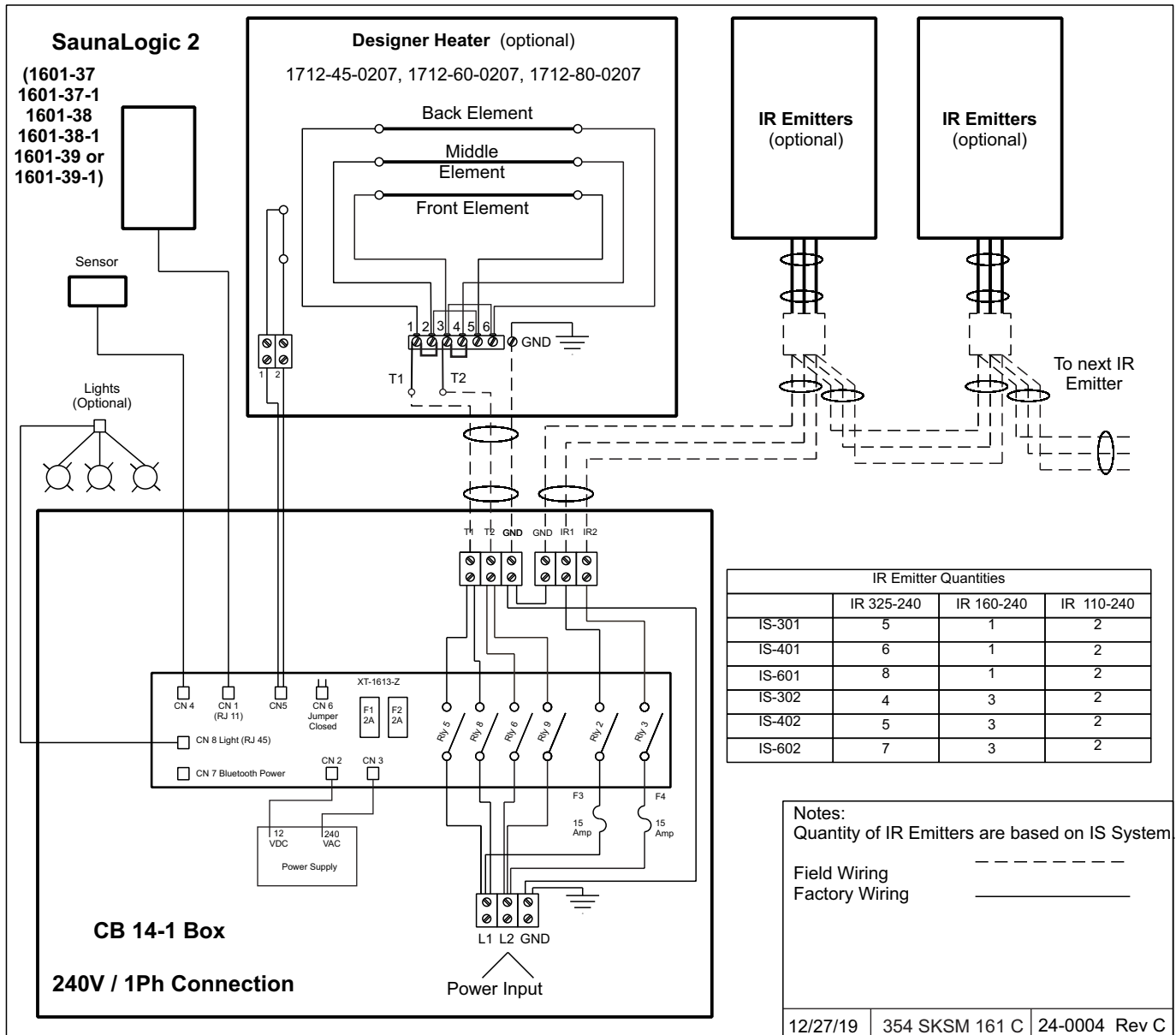

DIAGRAM 8 CONT.

WIRING DIAGRAM: CONTROL AND HEATER MODELS **Designer Heaters (1712-45-02,1712-60-02,1712-80-02)** **with SaunaLogic 2 IS and CB 14-1 Box**



SECTION 2: INSTALLATION SUMMARY AND TIPS

ELECTRICAL: ROUGH IN:

Step 1: *What traditional sauna heater being installed in room?*

The traditional heater location must be chosen first. If the room is over 78" and the heater is hung on the wall and the IR assembly can be installed above the traditional sauna heater. There has to be 5" of clearance above the traditional sauna heater and the bottom of the IR assembly. See Diagram 1 for specific spacing requirements.

Step 2: *What IS system should be installed in the room?*

The system will determine how many IR emitters will be in the room. See Diagram 7 for the quantities of IR emitters. Try to evenly space the IR emitters in the room behind the benches. See Diagram 3 for IR emitter size information.

Step 3: *IR Panel Wire Installation*

Pull 14-2 AWG wire w/ground BX cable from the CB Box to closest IR emitter. Install a metal single gang junction box 24" below the bottom of the estimated height of the IR heating panel. Daisy chain the wire from the first IR emitter to the next junction box and continue to loop and leave wires sticking out for each single gang box.

Step 4: *Traditional Sauna Heater Wiring* traditional sauna heater. Refer to Diagram 2 for the traditional sauna heater for wire size. Preinstall wire from the CB box to the location of the bottom of the sauna heater.

A two conductor cable is provided with the sauna heater for the high limit safety switch. Preinstall wire in the wall. *The traditional sauna system will not work if the wires and switch are not connected.*

Step 5: *Lighting Installation (Optional Equipment)* SaunaLogic 2 IS is capable of operating ONLY a lighting package purchased with the system. The lighting package consists of 3 lights or more with a maximum 6 lights and the cables to connect the light assemblies to the CB box. The long cable (5 m) connects the CB Box to a "splitter" device which typically is installed above the room ceiling. From the splitter there are cables (2 m) which connect the light assemblies to the splitter. All cable lengths for lights are similar depending on the number of fixtures.

Predetermine light fixture locations in the ceiling based on cable lengths and CB box location. Route the cable provided from the desired light locations in the ceiling to the CB box before any tongue and groove is applied.

Cut 2 3/4" holes in tongue and groove boards for light fixtures as the tongue and groove is being applied. Ensure the lighting cables reach the hole locations.

WARNING

Refer to Diagram 1 for minimum clearance of ceiling above heater.

Fire sprinkler systems used inside any sauna room should be properly rated for sauna room temperatures.

Do not spray water on Infrared Emitters

Water use on Infrared Emitters may cause damage and will void warranty.

Do not install a shower in the sauna room.

Electric Shock Hazard - High voltage exists within this equipment. There are no user serviceable parts in this equipment.

All installation and service to this equipment should be performed by qualified licensed personnel in accordance with local and national codes.

Use only copper wire of the size and type indicated in the Heater Specification Chart and the temperature rating indicated on the heater junction box.

All heaters and controls must be grounded per NEC to prevent electrical shock in case of unit failure.

Electrical outlets or receptacle must not be installed in a sauna room.

SECTION 3: TEMPERATURE SENSOR

Locate top of sensor 2" from ceiling and directly above the IR-325-240 IR panel AND traditional sauna heater if installed. (See Diagram 2 or 3 for details).

Feed the 17 ft "low voltage" sensor wire from the sensor location to the CB PK box location. Sensor wire must be routed completely separate (as per low voltage electrical wiring codes) from any wiring carrying over 50 volts. It may be necessary to drill holes to string the wire through the studs or ceiling joists.

Using a flat tip screwdriver, unsnap sensor cover from sensor. Mount sensor to a finished wall directly above heater and two (2) inches down from ceiling using two (2) screws (provided) as shown in Diagrams 1, 3 & 5.

Connect wires to CN 4 on the circuit board inside the CB box.

SECTION 4: ROOM AND ELECTRICAL INSTALLATION

ROOM ROUGH IN FOR SURFACE MOUNT IR EMITTERS:

Build the frame the room with standard building materials and framing design.

Install single gang outlets below the IR Emitters. Rough in all lighting wires, IR emitters wires, Sensor wire, Control wires before insulating the room and applying foil vapor barrier.

Tongue and groove the ceiling. While installing the tongue and groove on the ceiling continue to cut in the light holes and install and connect the lights as the ceiling is installed. Access will be difficult after ceiling is completed.

Apply tongue and groove wood on the walls (vertical or horizontal depending desires installation). Cut wood around the electrical access boxes. Cut an electrical access behind the IR Emitter to feed the wire from the emitter into the electrical box. Pictures do not show the cut out behind IR emitter.

Remove the cover from Surface Mount IR Emitter by holding the wire on the back of emitter and pull the cover away to the front. It will release a mechanical lock. Install the wire from the IR emitter into the wall and into the electrical box below. Install the extra wire in the wall and then attach IR emitter panel to the wood wall with 6 screws (3 on each side).

Reinstall the cover by placing the top of cover over the IR panel and pull down. It will catch two notches at the top of the wall and then push the lower part of the cover against the IR panel and the cover will "click" into place. The cover will be flush all the way around the IR emitter for clean finished look.

Splice in the electrical panels into the electrical box and cover with metal single gang blank plate.

Continue this process to complete the room.



SECTION 4: ROOM AND ELECTRICAL INSTALLATION (Cont)

Surface Mount IR Emitter Installation

Remove the cover from the IR panels by pushing the front bottom of the panel through the cloth.

Install the wire harness from the IR emitters into the wall to the pre-installed single gang boxes. Connect all wires in the electrical junction box appropriately. All IR emitters should be grounded.

Install the IR assembly to the tongue and groove wall with 6 wood screws provided with the kit. Ensure the excess wire is pushed in the wall behind the IR emitter.

Clip the cover over the top of the heater and push the bottom of the cover against the mechanical clips.

SECTION 5: ELECTRICAL CONTROLS INSTALLATION

Electrical installation must be made by a licensed electrician in accordance with the National Electrical Code and local regulations.

Remove the screws from the CB box to access the electrical connections. Secure CB box to the wall in the sauna room according to Diagram 1. (4 screws provided in the box) Route the wires through the holes provided on the bottom of the control box and connect the wires to the terminal block. To determine the correct wire size, refer to Diagram 2. Use copper supply wire only, suitable for minimum 90 degrees C. The heater must be grounded! See Diagram 7 and 8 for proper connections.

Refer to the Installation and Operation Manual for all electrical questions about the traditional sauna heater.

Connect low voltage cable from the SL2 IS control to *CN1* of the circuit board in the CB Box. Connect sensor cable to *CN4* of the circuit board in the CB Box. Connect the light cable to *CN 8 (RJ 45 Jack)* on the circuit board in the CB Box.

Connect the traditional sauna heater high limit sensor cable to *CN5* of the circuit board in the CB Box.

INSTALLATION ROUGH IN The SL2 IS (1601-37) control can be mounted inside or outside the sauna room. (See Diagram 3)

To mount the control cut an opening 2-3/4" wide by 4-3/4" tall. Route the control wire from CB Box to the control. (See Diagram 9 and 10)

Note: Use the factory supplied cable only! Do not staple through or otherwise damage the cable!

Connect the control cable to the SL2 IS and secure the control to the wall by 2 mounting screws provided.

Connect the other end of the control cable through the electrical access hole on the bottom of the control box and connect it to *Cn1*.

DIAGRAM 9

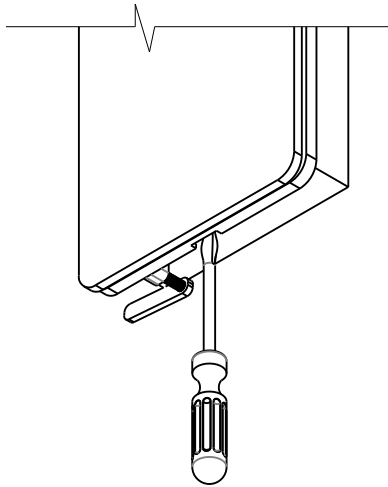

DIAGRAM 10

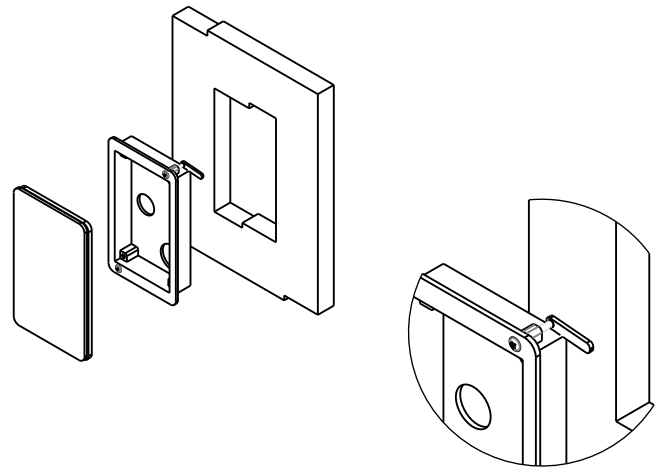

DIAGRAM 11

HEATER SCREEN (GUARD RAIL)

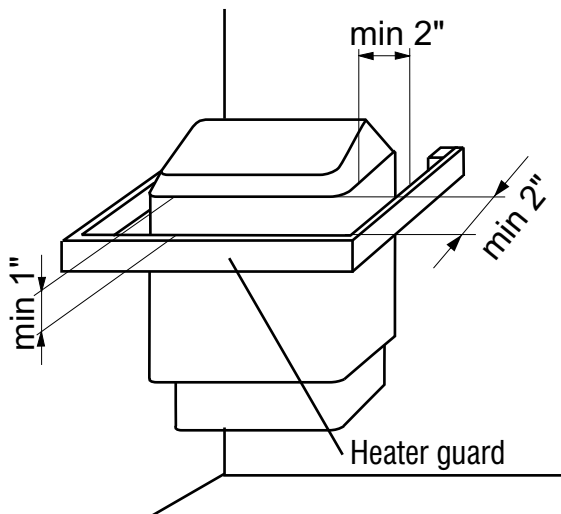
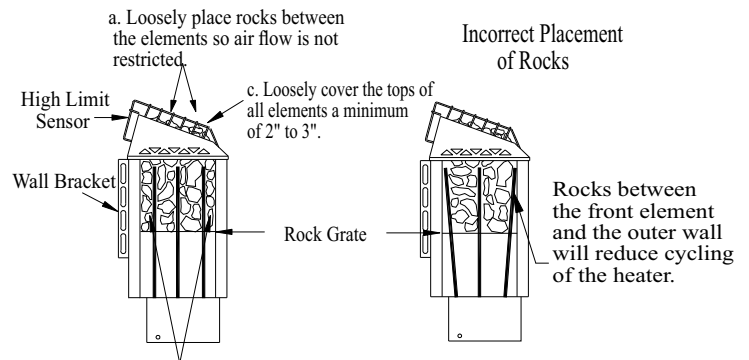

DIAGRAM 12



b. Rocks must be placed between the elements and the wall of the rock compartment.

1. Put smaller rocks in first around the outer perimeter of the heating chamber.
2. Completely fill all four sections (front, 2 center sections between elements, and back).
3. In the outer sections, use smaller rocks placed more tightly (see note b).
4. Place rocks loosely in the center 2 sections (see note a).
5. Be sure rocks completely cover the elements (see note c).
6. Loosely cover the tops of all elements a minimum of 2" to 3".

SECTION 6: SAUNALOGIC 2 IS CONTROL OPERATION

MODEL SL2 IS 60 MIN CONTROL PANEL (1601-37)

PRE-SET DELAYED START

Press the  icon and delay time will appear in the display and will toggle between “dlay” the amount of time remaining. The maximum of time is 24 hours. If no delay is desired, press button to toggle off the function.

 BlueTooth

 Decrease

 Traditional

 Lights

 Heat Time

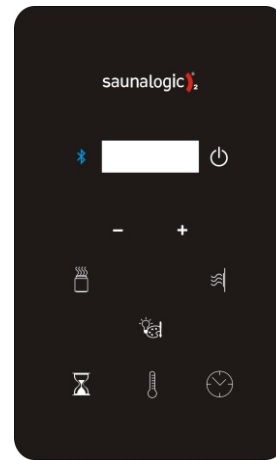

Power 



Increase 

Infrared 

Delay 

Temperature 

Traditional Sauna Operation

Press the SL2 IS  icon once and press the  icon. The default settings for the temperature is 194°F, the bath time is 60 minutes. These settings are adjustable (as described below) from 119° to 194°. Length of sauna can be set from 0 to 60 minutes. The time delay before start can be up to 24 hours. Any changes are remembered by the heater for your next bath. Should the heater power be lost then restored, the settings will return to their default values.



SETTING THE DURATION AND TEMPERATURE

Press the  icon for time "+" or "-" icon to increase or decrease time for desired setting. The maximum of time is 60 minutes.

Press the  icon and then press "+" or "-" icon to increase or decrease temperature for desired setting. The maximum temperature is 194°F (90°C).

Note: Typical bathing temperature is 150F to 165F displayed on the control.

Infrared Sauna Operation

Press the SL2 IS  icon once and press the  icon. The default settings for the temperature is 149°F, the bath time is 60 minutes. These settings are adjustable (as described below) from 110° to 149°. Length of sauna can be set from 0 to 60 minutes. The time delay before start can be up to 24 hours. Any changes are remembered by the heater for your next bath. Should the heater power be lost then restored, the settings will return to their default values.

SETTING THE DURATION AND TEMPERATURE

Press the  icon for time "+" or "-" icon to increase or decrease time for desired setting. The maximum of time is 60 minutes.



Press the  icon and then press "+" or "-" icon to increase or decrease temperature for desired setting. The maximum temperature is 149°F (65°C).

Note: Note: Typical bathing temperature is 115F to 125F displayed on the control.

Starting ambient temperature below 70F will cause the IR system to heat slower, which may result in less effective performance.

SECTION 6: OPERATION, Continued

LIGHTING OPERATION (Equipment Optional)

Press the  icon to cycle through lighting options. Press and hold the  icon for 3 seconds to turn off the light from during any color. Light will automatically turn off after 10 minutes the sauna cycle is completed.

Color sequence – White – Red – Green – Blue – Yellow – Aqua – Purple –
Rotation of Colors - Off

Choose the color of choice and then set lighting brightness. The brightness will be on display for 3 seconds. Press the “+” or “-“ button to increase or decrease the light setting. The setting options are 25, 50, 75, and 100% light output.

MODEL SL2 IS 24 HR CONTROL PANEL (1601-37-1),

The control operates the same as the 60 minute version except the time is in Hours instead of minutes.

An attendant must be present at all times for extended period of time operation.

SECTION 7: HIGH LIMIT CONTROL (RESET BUTTON)

The sauna systems have a built-in high limit control, which automatically turns off the heater if the temperature inside in the sauna room rises to an abnormally high level.

The control will display "HL" if the system overheats. To restart the heater, let the room cool, then push the "On/Off" button on the control. If the high limit continually shuts off the heater, contact a service representative at 1-888-780-4427.

SECTION 8: HOW TO TAKE A SAUNA

- When taking a sauna, allow time to relax completely.
- Remove clothing and jewelry...if required, wear a towel loosely.
- After 10 minutes or when perspiration begins, leave sauna and relax in dressing area...follow with a cool shower.
- Cooling time should equal time spent in sauna. Enter sauna room again and stay 5 or 10 minutes.
- Repeat the cycle 2 or 3 times; end with a brisk shower...rinse in cool water.
- Dress when completely dry and perspiration has stopped.
- Do not smoke, exercise or drink alcoholic beverages in the sauna room.

SECTION 9: WARNING PLACARDS

Three metal placards are included in the Installation Instruction Envelope packaged with every Sauna Heater. The CAUTION placard (English with French) must be attached to the interior wall of the sauna room directly above the heater where it is visible to the bather. The WARNING placards (English and French) must be attached to the door of the sauna room.



Shower



Sauna (10 - 15 min.)



Shower or swim



Rest (10 - 15 min.)



Relax with juice or water

You liked it?
Do it once again and
you will feel great.

SECTION 10: MAINTENANCE

Inspect sauna room at the end of each day the room is in use.

The sauna, like a bathroom, should be kept clean and odor free. Towels or mats should always be used on benches and floor as perspiration otherwise penetrates the soft wood. To clean and remove perspiration stains, use soap or detergent in warm water, best applied with a scrub brush. Badly soiled surfaces may require sanding. Sand paper wrapped around a wooden block works well.

Air out the sauna often by keeping the door and vents open when the sauna is not in use. Saunas that are in daily use should be washed down at least once a week to keep them clean and the air fresh. Duckboard should be removed from the sauna, the sauna floor mopped and dried in a conventional manner, and the duckboard thoroughly scrubbed and dried before returning to the sauna room. The sauna heater should be wiped down occasionally with a damp cloth to remove lint and dust. The rocks should be removed once a year for cleaning and small or crumbled rocks replaced.

Benches and supporting structure must be inspected annually for potential deterioration due to age, dry rot or abuse. Any boards with signs of deterioration should be replaced immediately to avoid possible injury.

SECTION 11: ROOM CONSTRUCTION

- For safety and reliability, the following rules must be addressed.
- No permanent locking or latch system is to be used on the sauna door.
- Acceptable door fittings are: magnetic catches, friction catches, spring or gravity loaded closures.
- The door must always open outwards.
- No shower may be installed in a sauna room.
- No electrical receptacle shall be installed inside the sauna room.
- The enclosed WARNING: Reduce the risk of overheating ... warning plate must be mounted on or alongside the door outside the sauna room at about eye level.
- The enclosed CAUTION: Reduce the risk of fire ... caution plate must be mounted on the interior wall above the heater.
- The heater should not be operated without its container properly filled with rocks and the rock guard in place.
- If an intercom speaker is installed, it should be away from the heater and as close to the floor as possible.
- Fire sprinkler systems installed inside any sauna room should be properly rated for sauna room temperatures.
- Always mount the heater according to these installation instructions.
- Minimum of R12 insulation in 16" on center 2x4 stud walls.
- Recommended minimum flooring thickness of 5/8".

WARNING

The "CAUTION" and "WARNING" placards must be mounted in accordance with Section 10.



WARNING
REDUCE THE RISK OF OVERHEATING

- * Exit immediately if uncomfortable, dizzy, or sleepy. Staying too long in a sauna is capable of causing overheating.
- * Supervise children at all times.
- * Check with a doctor before use if pregnant, in poor health, or under medical care.
- * Breathing heated air in conjunction with consumption of alcohol, drugs, or medication is capable of causing unconsciousness.



CAUTION
REDUCE THE RISK OF FIRE

Do Not Place Combustible Material On The Heater At Any Time.

For safety purpose sauna door must open out and not lock.

Never use a wood stain, seal or preservative on the inside of your sauna room.

Light fixtures get very hot during operation. Locate light fixture where it will not be a burn hazard.

DIAGRAM 13

DIAGRAM 14

TYPICAL PRE-CUT WALL CONSTRUCTION

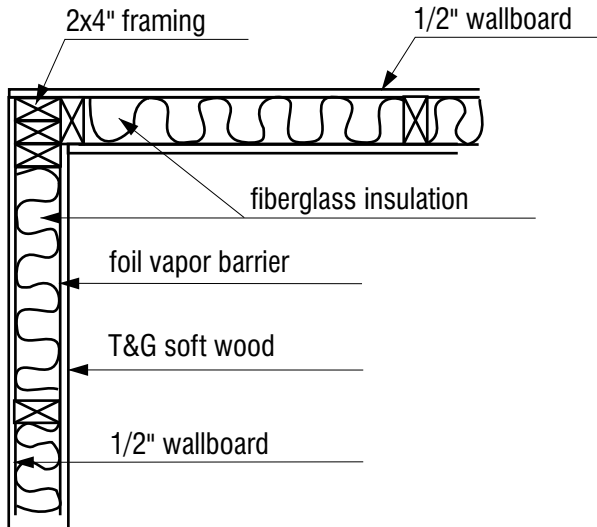

VENTILATION

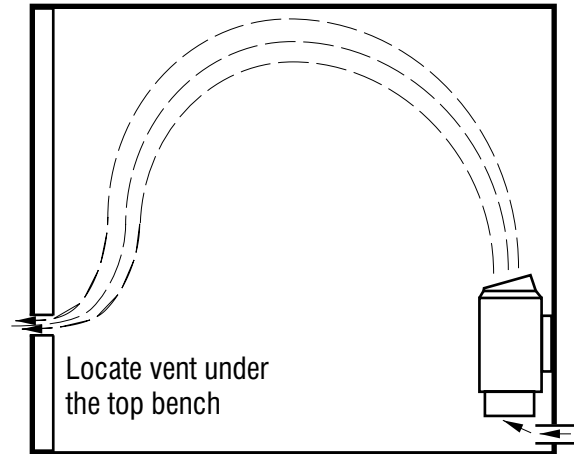

SECTION 12: VENTILATION

VENTILATION In a private sauna, the air should be changed about 6 times an hour. This can be achieved by making a vent opening (fresh air inlet) in the sauna wall directly below the heater. The air outlet must be lower than the upper benches, as far as possible from the heater and about two feet higher than the fresh air inlet vent, See Diagram 9. It is recommended that ventilation openings meet the requirements of UL Specification 875. The minimum opening should be determined using one of the following formulas:

For $R < 31$, $V \geq 9.3$, For $R \geq 31$, $V \geq 0.3R$
 where R = the floor area of the room in square feet and
 V = the minimum vent size in square inches

SECTION 13: TROUBLESHOOTING

If control displays "Sn" it means no sensor is connected. Refer to Section 5 for sensor installation information.

If control displays "HL" it means the high limit is open. Refer to Section 9 for high limit information.

System won't start to heat, ensure the system is not in the delay mode. If "dLAY" is flashing in the display window, the system is in the delay mode.

If control displays "JP" it means the jumper is open on the main board in the CB Box. Verify jumper is installed in CN6 location on the main board. If it is open, close the two pins.

If control acts erratically or buttons turn on and off by itself during startup. Turn power off at the circuit breaker, place the glass on the control and turn power back on the system. The control will automatically reset the sensitivity of the capacitive switches.

CAUTION: Use only a contactor approved for 250,000 endurance Cycles / **ATTENTION:** Utiliser uniquement un contacteur approuvé pour 250,000 cycles de fonctionnement

For troubleshooting or service questions call 1-888-780-4427 and ask to speak with service. Prior to calling, please have the Model and Type number available. You may also email us at us_techsupport@sauna360.com

DIAGRAM 14: SL2 Control Mounting

Recessed Mounting For the SL2 Control

The recessed mounting box allows the control to mount with its surface almost even to the wall surface. Print this page to “Actual” Size on Printer Options. This will ensure the size of the opening is correct. Cut out the middle of this page on the dotted lines. The hole will be the size of the mounting box. Insert the mounting box in the hole of this page to ensure it is the correct size.

Trace the paper cut out on the wall. Cut a hole in the wall to match the inner dotted line for the mounting box. Run the control cable out of the wall through the hole in the mounting box. Ensure the hole is just big enough to mount the box. Push the mounting box into the hole and turn the mounting screws to pull the tab tight against the inside of the wall. Ensure the box is level and the correct end is UP (there is an arrow on the wall side of the box pointing up).

Connect the Control coupler to the control cable then feed the cables and connector through the hole in the box and into the wall. Test the Control before mounting it into the wall.

Hang the top of the control glass on the top of the recessed box and press the bottom of glass to snap on to box.

